



Permanent-Magnet-Spannfutter Permanent magnetic circular chuck

Eclipse-Magnetspannfutter sind hervorragend geeignet zur Verwendung auf Drehbänken, auf Innenschleifmaschinen, Zylinderschleifmaschinen und Rundtischschleifmaschinen.

The magnetic circular chucks Eclipse, are particularly suitable for use on the turning lathe, on internal grinding machines, for cylindrical-grinding machines, and on circular-indexing machines.



AX65/1C

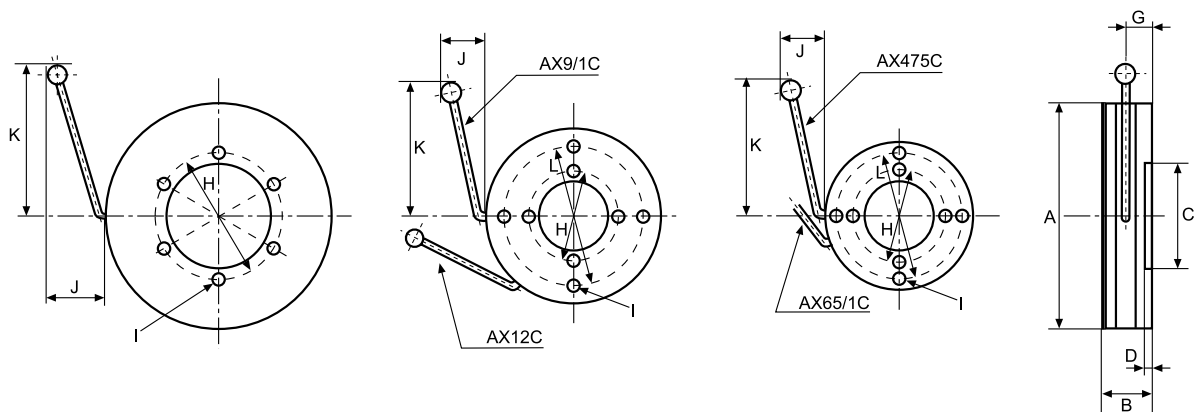

Abmessungen/ Dimensions
mm

Gewicht
Weight
kg

	A	B	C	D	G	H	I	J	K	L	
AX475C	120	45	50.8	6	22	76	M 6	46	79	102.0	4.0
AX65/1C	165	57	76.2	4	28	102	M10	73	130	140.0	9.0
AX9/1C	229	60	85.725	5	29	114	M10	73	137	190.5	18.0
AX12C	305	76	152.4	5	37	184	M12	105	257	254.0	42.0
AX15C	381	83	196.85	8	40	235	M12	98	256	—	68.5



Zusatzplatten zu Magnet-Spannfutter
Additional plates for the magnetic
circular chuck

Zu verwenden als aufschraubbare Polplatte für
den Vorrichtungsbau.

Used as a screwed on pole plate, for the con-
struction of jigs and fixtures.

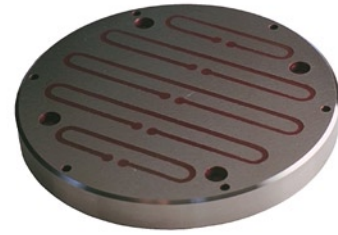

T65/1C

	Passend zu for plates	Dicke Thickness mm	Gewicht Weight kg
T475C	AX475C	13.0	1.140
T65/1C	AX65/1C	16.0	2.130
T9/1C	AX9/1C	15.0	4.800
T12C	AX12C	23.5	13.600
T15C	AX15C	23.5	22.000